

DIMENSIONAL SPECIFICATIONS

INDOOR UNIT DIMENSIONS

Units: inch

Model No: dt32

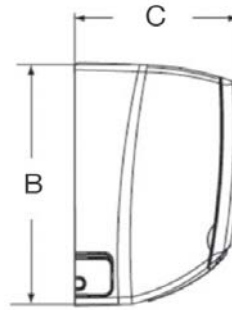
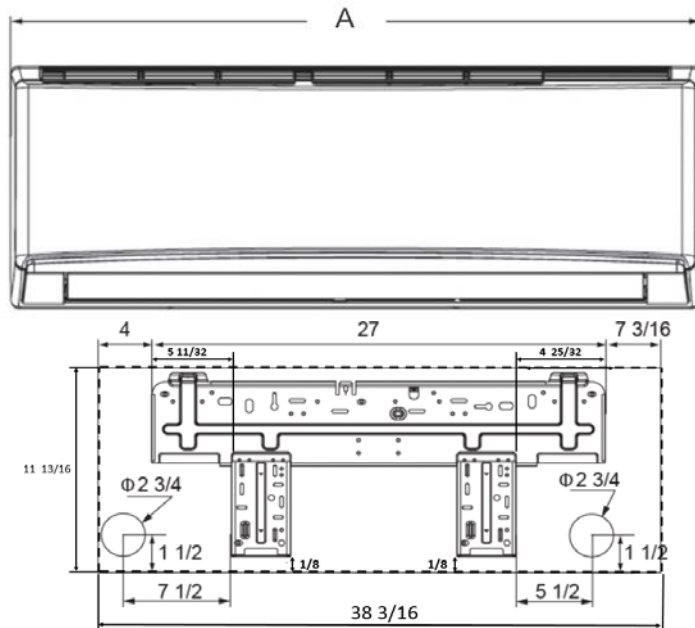

Dimensions	
A	38.2
B	11.8
C	8.9

Weight (Net/Shipping) 29.8/36.4 LBS

Liquid Line Valve	1/4-in OD Flared
Gas Line Valve	1/2-in OD Flared
Drain Connector	5/8-in OD

OUTDOOR UNIT DIMENSIONS

Units: inch

Model No: dt32

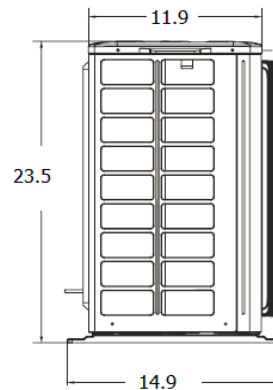
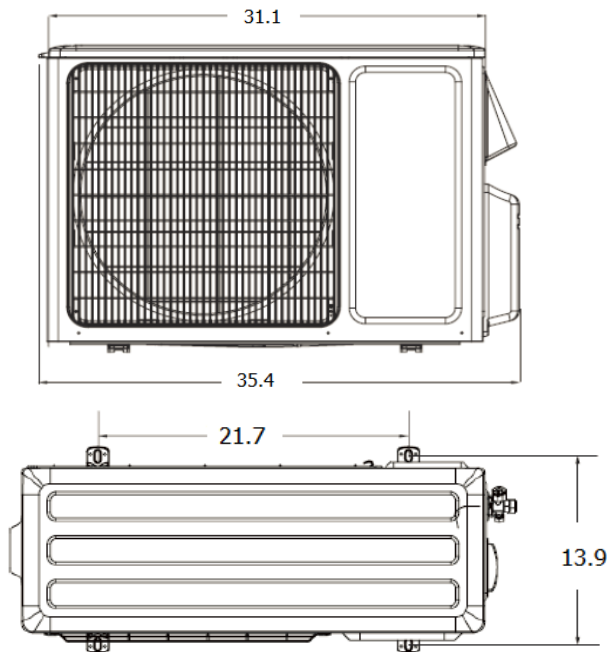

Liquid Line Valve	1/4-in OD Flared
Gas Line Valve	1/2-in OD Flared

Weight (Net/Shipping) 99.2/105.8 LBS

Notes:

1. Recommended Interconnecting Cable Type 14 AWG 4 Stranded Copper Conductors THHN 600V Wire
2. Power wiring cable size must comply with applicable national and local codes.
3. Test conditions are based on AHRI 210/240.

Specifications are subject to change without notice. Manufacturer reserves the right to discontinue or modify specifications or designs without notice or without incurring obligations. All rights reserved.