

**Submittal Data:**  **9,000 BTU/H (208/230V) Wall Mounted Heat- Pump System**

Job Name \_\_\_\_\_ Location \_\_\_\_\_ Date \_\_\_\_\_

Purchaser \_\_\_\_\_ Engineer \_\_\_\_\_

Submitted To \_\_\_\_\_ For  Reference  Approval  Construction

Unit Designation \_\_\_\_\_ Schedule No. \_\_\_\_\_

- GENERAL FEATURES**
- Compact and Quiet Design
  - High Efficiency DC Inverter Technology
  - Vertical Swing Louver
  - Wireless Remote with LCD Display
  - XK-41 Wired Tether Controller ( Sold Separately)
  - Low Ambient Cool to 0 deg F
  - Blue Fin Condenser Coil
  - 5 year Limited Parts Warranty
  - 7 year Limited Compressor Warranty



**System Ratings** **Indoor Unit Data**

<b>Cooling</b>		
Rated Capacity		9,000 BTU/H
Capacity Range		3,100-9,600 BTU/H
Power Input (Max)		1,300 W
SEER		23.0
EER		14.0
<b>Heating at 47° F</b>		
Rated Capacity		11,000 BTU/H
Capacity Range		1,911-12,000 BTU/H
Power Input (Max)		1,350 W
HSPF		11.0
COP		3.2
<b>Heating at 17° F</b>		
Rated Capacity		6,800 BTU/H
<b>Operating Range</b>		
Cooling	(Max)	115°F (46 C)
	(Min)	0°F (-18 C)
Heating	(Max)	75°F (24 C)
	(Min)	-4°F (-20 C)

<b>Fan Motor</b>	Type	Cross-Flow
	Output Power	20 W
	FLA	0.1 A
<b>Airflow</b>		
Cooling	Wet (Lo/Hi)	171/377 CFM
Heating	Dry (Lo/Hi)	171/377 CFM
<b>Sound Pressure Level</b>		
Cooling	(Min/Max)	29/43 db(A)
Heating	(Min/Max)	29/43 db(A)
<b>Dehumidification</b>		1.69 pt/hr

**Refrigerant Piping Data**

Gas Pipe Size (OD)	3/8-in
Liquid Pipe Size (OD)	1/4-in
Connection Method	Flared
Factory Charge	45.9 oz
Additional Charge	0.16 oz
Pre-Charge Length	25-ft
MAX Refrigerant Pipe Length	50-ft
MIN Refrigerant Pipe Length	10-ft
MAX Refrigerant Pipe Elevation	33-ft

**Outdoor Unit Data**

<b>Compressor</b>	Type	DC Inverter Driven Rotary
	RLA	6.6 A
<b>Refrigerant Type</b>		R410A
<b>Fan Motor</b>	Output Power	30 W
	FLA	0.36 A
<b>Sound Pressure</b>		
Cooling/Heating		53/53 db(A)

**Electrical Data**

<b>Power Supply</b>		
Normal Operational Voltage	208/230 V, 1 Phase, 60 Hz	
Voltage Range	187 - 253 V	
MCA	9.0 A	
MOCP/Breaker Size	15 A	
Main Power Wire Size	14-2 AWG	

**EXTENDED RATINGS**

**COOLING PERFORMANCE (BtuH)\***

Outdoor Ambient DB	Indoor Ambient Temperature							
	68F DB (20C)		73F DB (23C)		80F DB (27C)		82F DB (28C)	
	57F WB (14C)		61F WB (16C)		67F WB (19C)		68F WB (20C)	
	TC	SHC	TC	SHC	TC	SHC	TC	SHC
5°F	5,748	4,508	6,073	4,761	6,854	5,375	6,914	5,423
14°F	5,896	4,624	6,226	4,883	7,115	5,579	7,178	5,629
23°F	6,298	4,940	6,736	5,284	7,719	6,054	7,787	6,108
32°F	7,637	5,990	8,169	6,407	8,947	7,015	9,026	7,077
41°F	8,650	6,784	9,190	7,207	9,821	7,703	9,908	7,771
50°F	8,547	6,705	9,091	7,131	9,731	7,633	9,817	7,700
59°F	8,337	6,538	8,878	6,963	9,641	7,563	9,726	7,630
68°F	8,127	6,373	8,668	6,799	9,461	7,420	9,545	7,486
77°F	7,920	6,212	8,457	6,632	9,280	7,280	9,363	7,344
86°F	7,692	6,033	8,229	6,452	9,010	7,067	9,090	7,130
95°F	7,505	5,887	8,040	6,306	8,893	6,976	8,972	7,038
104°F	7,319	5,740	7,854	6,160	8,776	6,884	8,854	6,945
113°F	6,944	5,445	7,478	5,865	8,403	6,589	8,478	6,648

**HEATING PERFORMANCE (BtuH)\***

Outdoor Ambient DB	Indoor Ambient Temperature							
	68F DB (20C)		73F DB (23C)		80F DB (27C)		86F DB (30C)	
	57F WB (14C)		61F WB (16C)		67F WB (19C)		72F WB (22C)	
	TC	SHC	TC	SHC	TC	SHC	TC	SHC
-4°F	5,772	5,772	5,717	5,717	5,620	5,620	5,393	5,393
0°F	6,253	6,253	6,194	6,194	6,091	6,091	5,840	5,840
6°F	6,597	6,597	6,535	6,535	6,425	6,425	6,160	6,160
10°F	6,872	6,872	6,806	6,806	6,693	6,693	6,418	6,418
16°F	7,078	7,078	7,013	7,013	6,896	6,896	6,610	6,610
19°F	7,219	7,219	7,147	7,147	7,030	7,030	6,738	6,738
24°F	8,020	8,020	7,951	7,951	7,831	7,831	7,542	7,542
32°F	8,955	8,955	8,886	8,886	8,766	8,766	8,477	8,477
41°F	10,024	10,024	9,955	9,955	9,838	9,838	9,546	9,546
43°F	10,292	10,292	10,223	10,223	10,103	10,103	9,814	9,814
47°F	11,223	11,223	11,110	11,110	10,918	10,918	10,443	10,443
53°F	11,337	11,337	11,220	11,220	11,024	11,024	10,546	10,546
59°F	11,595	11,595	11,478	11,478	11,275	11,275	10,787	10,787
64°F	11,842	11,842	11,722	11,722	11,516	11,516	11,017	11,017
70°F	12066	12066	11942	11942	11736	11736	11227	11227
75°F	12234	12234	12110	12110	11897	11897	11382	11382

\* Maximum system capacity

TC- Total Capacity ( BtuH)

SHC- Sensible Capacity (BtuH)

# DIMENSIONAL SPECIFICATIONS

## MINIMUM SPACING REQUIREMENTS

Units: inch (mm)

### INDOOR

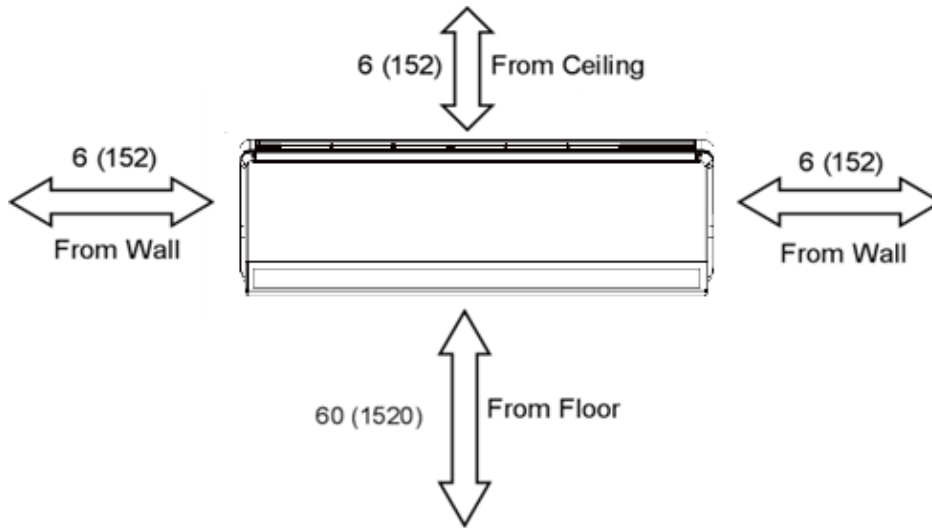

Units: inch (mm)

### OUTDOOR

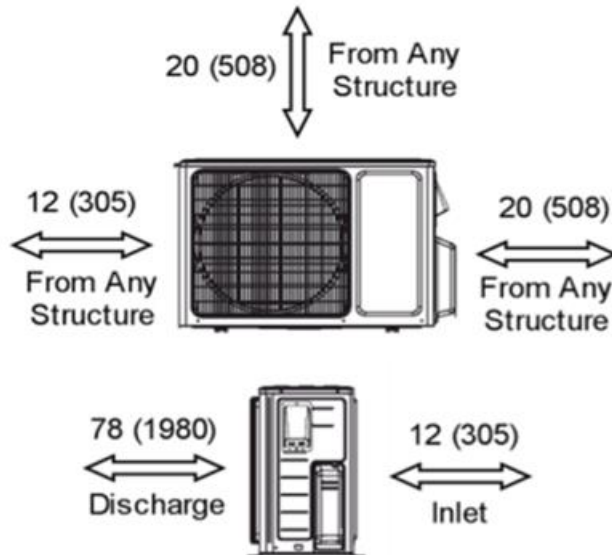

## DIMENSIONAL SPECIFICATIONS

### INDOOR UNIT DIMENSIONS

Units: inch

Model No: TW09HQ2C2DI

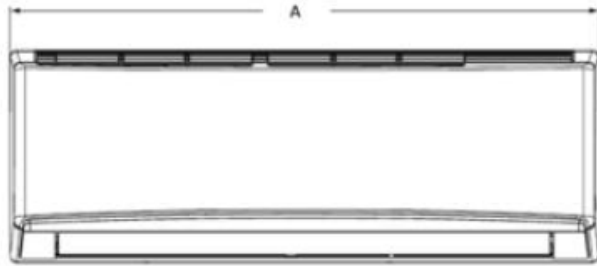

Dimensions	
A	33.4
B	11.4
C	8.2

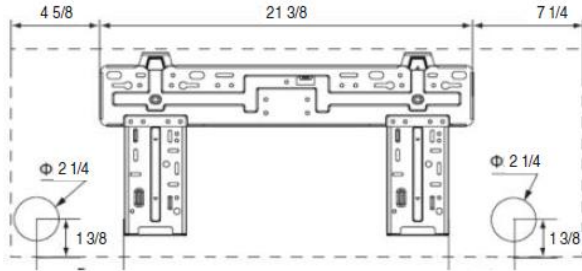

Weight (Net/Gross) 22.1/26.5 lbs

Liquid Line Valve	1/4-in OD Flared
Gas Line Valve	3/8-in OD Flared
Drain Connector	5/8-in OD

### OUTDOOR UNIT DIMENSIONS

Units: inch

Model No: TW09HQ2C2DO

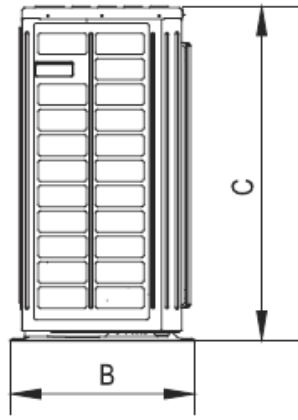
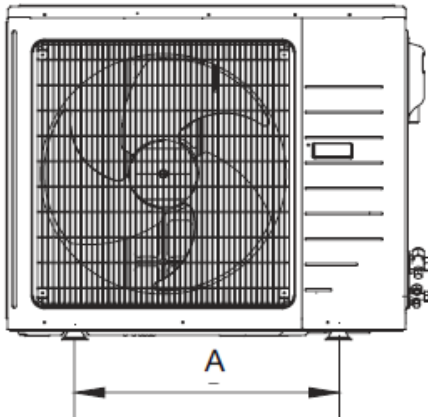

Dimensions	
A	21.3
B	12.6
C	21.3
D	33.4
E	11.3

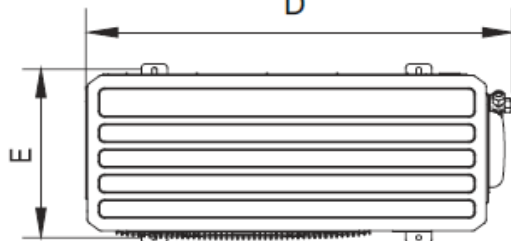

Weight (Net/Gross) 78.0/84.0 lbs

Liquid Line Valve	1/4-in OD Flared
Gas Line Valve	3/8-in OD Flared

**Notes:**

1. Recommended Interconnecting Cable Type 14 AWG-4 Stranded Copper Conductors THHN 600V Wire
2. Power wiring cable size must comply with applicable national and local codes.
3. Test conditions are based on AHRI 210/240.